

Tank Model: 1300 litre insulated	Product Codes: ECO1300INS & ECO1300INSPOT
Name:	Date:

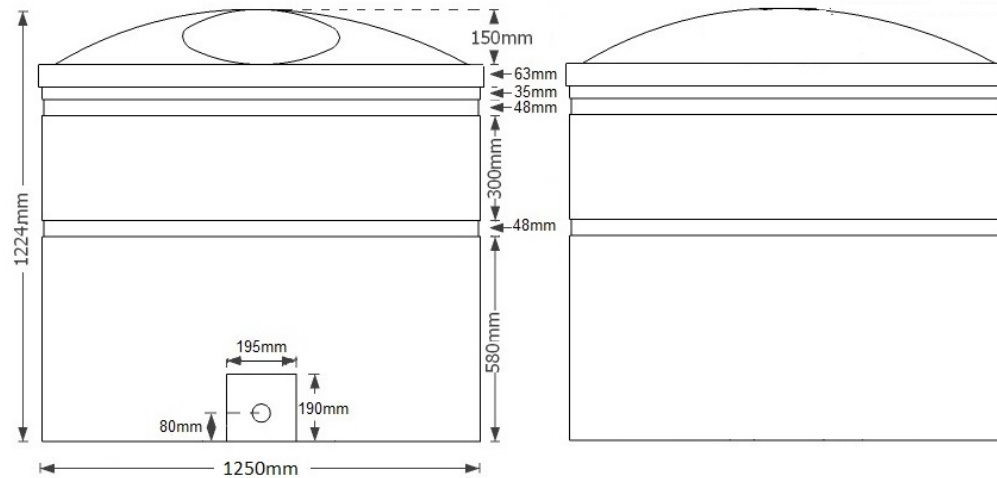
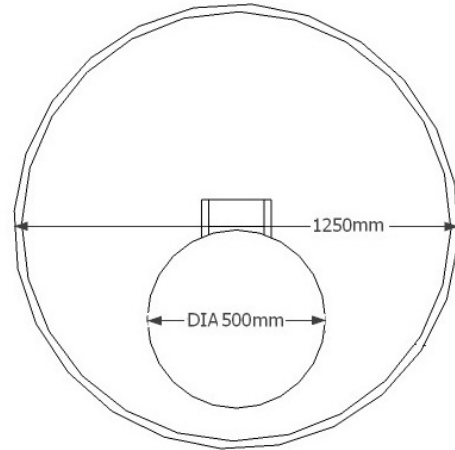

Please mark full details of all the additional connections you require on the diagram, stating sizes, distance from the edges, etc, and labelling the connections.

CUSTOMER DECLARATION:

I confirm that the information provided is accurate. I understand that the tank is non-returnable.

Signed:

Please return this form to sales@ecosure.co.uk