

ECO1000TA

Product description: cylindrical storage tank with fully removable lid, suitable for internal or external use

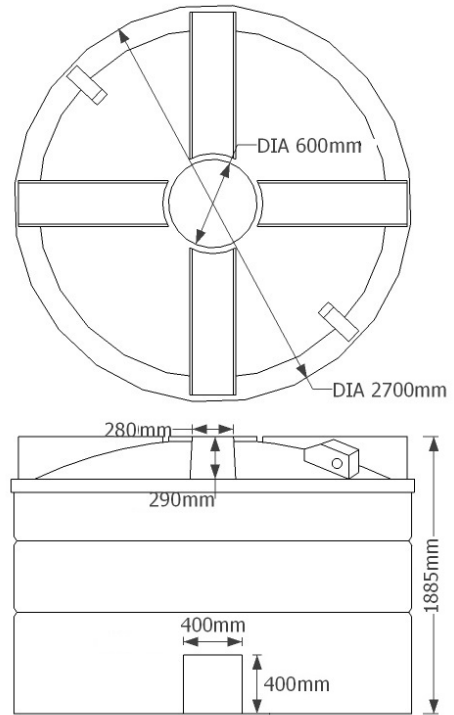
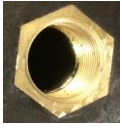

Product Information				
Height	Diameter	Lid	Weight	Outlet
1885mm	2700mm	24" screwdown on removable lid	180kg	Supplied loose

Sizes approximate, owing to shrinkage
Specification subject to change; please call to confirm details

PRODUCT NOTES:

- Tank must be sited on a level, fully supportive base leaving a gap of at least 50mm from walls or other tanks
- No additional pressure can be placed on tank sides or rim
- Additional fittings can be added as and where required without compromising tank's structural integrity
- Tank moulded blank with outlet supplied loose

PRODUCT DETAILS:

- Made from virgin polymer
- Approximate wall thickness: 5-6mm
- 24" screwdown lid/inspection hatch on fully removable lid as standard
- Plastic 2" male threaded outlet supplied loose
- Available in a variety of colours at additional cost

OPTIONAL EXTRAS:

- 16" lockable lid
- Tank connector (up to 4" BSP)
- Brass isolation valve
- Ball valve & float

BENEFITS:

- Full removable lid allows full access for cleaning, maintenance and fitting of ancillaries.
- Suitable for internal and external use
- Frost proof; will not crack in cold
- Value for money, high capacity storage
- Ideal for domestic or commercial water storage
- Robust, heavy duty product; industrial strength
- Opaque plastic reduces algae growth in sunlight
- Rotationally moulded for strength and durability
- 10 year warranty against manufacturing defects



Scan to view our full range of water tanks



Etills Ltd,
Unit 1 Whiting Way,
Melbourn,
Royston,
SG8 6NA



Call 01763 261781